

Metal Drywall Framing & Accessories

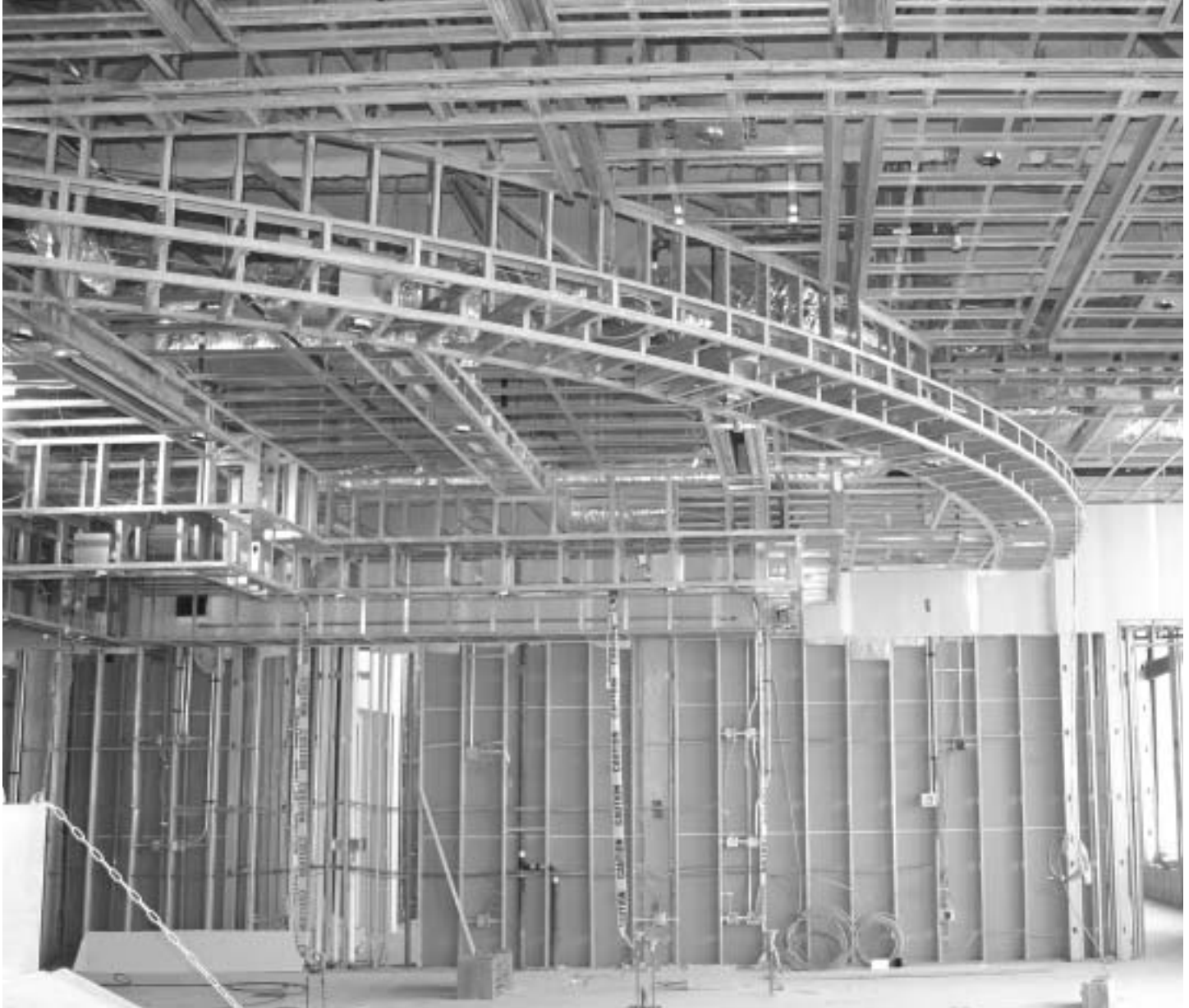

Telling Industries
2105 Larrick Road
Cambridge, OH 43725
Tel: 740-435-8900
Fax: 740-435-8915
www.tellingindustries.com

PRODUCT IDENTIFICATION

All Telling Industries products contain a four part identification code. This identifies the size (both depth and flange width), style, and material thickness of each member.

EXAMPLE:

MEMBER DEPTH:

(Example: 6" = **600** x 1/100 inches)
All member depths are taken in 1/100 inches.
For all "T" sections member depths is the inside to inside dimension.

FLANGE WIDTH:

(Example: 1 5/8" = 1.625" ~ **162** x 1/100 inches)
All flange widths are taken in 1/100 inches.

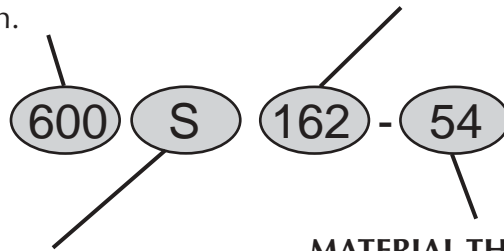

STYLE:

(Example: Stud or Joist section = **S**)
The two alpha characters utilized by the identification code are:
S= Stud or Joist Sections
T= Track Sections

MATERIAL THICKNESS:

(Example: 0.054 in. = **54** mils;
1 mil = 1/1000 in.)
Material thickness is the minimum base metal thickness in mils.
Minimum base metal thickness represents 95% of the design thickness.

Note: For those sections where two different yield strengths (33 ksi and 50 ksi) are shown, the yield strength used in the design, if greater than 33 ksi, needs to be identified on the design and ordering of steel. (i.e., 600S162-54(50 ksi))

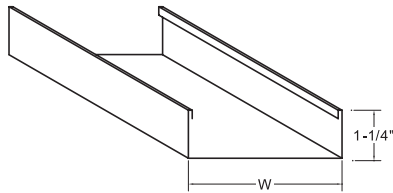

Table of Contents	Track.....	Page 2
	Studs.....	Page 3 & 4
	Accessories.....	Page 5 & 6
	General Product Information.....	Back cover

Telling Industries track is used to anchor the partition at the ceiling and floor. Tracks are roll-formed steel in a channel configuration with hemmed or unhemmed legs in 1" or 1-1/4" depths. Sections are manufactured to receive the corresponding size of the studs with an overbend for a friction fit. Telling Industries' standard 25, 22, and 20 gage track meets ASTM C-645, A568-00a, and A653. The properties and weights shown are calculated on minimum thicknesses in accordance to A.I.S.I. specifications.

Physical and Structural Properties

Hemmed Track



Low Leg Track

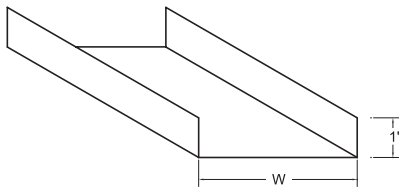

High Leg Track

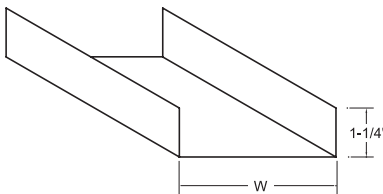

Note: Additional sizes and gages are available upon request.

20 Ga. Low Leg Track, 1" Leg, (Web) T 100-30

Part#	Web in.(1/100in.)	WT. (lb/ft.)	A (in4)	Ix (in4)	Sx (in3)	Ma (in-K)
162T100-30	1-5/8", (162)	0.38	0.113	0.058	0.065	0.95
250T100-30	2-1/2", (250)	0.48	0.140	0.146	0.111	1.69
362T100-30	3-5/8", (362)	0.60	0.175	0.341	0.181	2.88
400T100-30	4", (400)	0.64	0.187	0.429	0.207	3.33
600T100-30	6", (600)	0.85	0.250	1.142	0.372	5.34

20 Ga. High Leg Track, 1-1/4" Leg, (Web) T 125-30

162T125-30	1-5/8", (162)	0.44	0.129	0.07	0.079	1.00
250T125-30	2-1/2", (250)	0.53	0.156	0.173	0.131	1.77
350T125-30	3-1/2", (350)	0.64	0.187	0.365	0.200	2.86
362T125-30	3-5/8", (362)	0.65	0.191	0.395	0.210	3.01
400T125-30	4", (400)	0.69	0.203	0.495	0.239	3.49
600T125-30	6", (600)	0.90	0.265	1.288	0.419	5.37

22 Ga. High Leg Track, 1-1/4" Leg, (Web) T 125-27

162T125-27	1-5/8", (162)	0.40	0.117	0.063	0.072	0.87
250T125-27	2-1/2", (250)	0.48	0.141	0.157	0.119	1.56
350T125-27	3-1/2", (350)	0.58	0.170	0.331	0.182	2.53
362T125-27	3-5/8", (362)	0.59	0.173	0.358	0.191	2.66
400T125-27	4", (400)	0.63	0.184	0.449	0.217	3.08
600T125-27	6", (600)	0.82	0.241	1.168	0.381	4.44

25 Ga. Low Leg Track, 1" Leg, (Web) T 100-18

Part#	Web in.(1/100in.)	WT. (lb/ft.)	A (in4)	Ix (in4)	Sx (in3)	Ma (in-K)
162T100-18	1-5/8", (162)	0.23	0.068	0.035	0.040	0.48
250T100-18	2-1/2", (250)	0.29	0.085	0.088	0.067	0.88
350T100-18	3-1/2", (350)	0.35	0.103	0.189	0.104	1.22
362T100-18	3-5/8", (362)	0.36	0.106	0.205	0.110	1.26
400T100-18	4", (400)	0.38	0.113	0.259	0.125	1.38
600T100-18	6", (600)	0.51	0.151	0.689	0.225	-

25 Ga. High Leg Track, 1-1/4" Leg, (Web) T 125-18

162T125-18	1-5/8", (162)	0.26	0.078	0.042	0.048	0.51
250T125-18	2-1/2", (250)	0.32	0.094	0.105	0.080	0.90
350T125-18	3-1/2", (350)	0.38	0.113	0.221	0.122	1.25
362T125-18	3-5/8", (362)	0.39	0.115	0.240	0.127	1.30
400T125-18	4", (400)	0.42	0.122	0.300	0.145	1.43
600T125-18	6", (600)	0.54	0.160	0.776	0.254	-

25 Ga. Hemmed Track, 1-1/4" Leg, (Web) T 125-18

162T125-18-H	1-5/8", (162)	0.28	0.082	0.045	0.051	0.58
250T125-18-H	2-1/2", (250)	0.33	0.098	0.111	0.085	1.02
350T125-18-H	3-5/8", (362)	0.41	0.120	0.253	0.135	1.46
400T125-18-H	4", (400)	0.43	0.127	0.316	0.153	1.61
600T125-18-H	6", (600)	0.56	0.164	0.817	0.267	-

DRYWALL STUDS



Telling Industries roll-formed, channel shaped, non-load bearing steel members drywall studs are used exclusively for interior partitions. Outer flanges are knurled to prevent screw ride and to expedite attachment O.C. Telling Industries' 25, 22, and 20 gage studs meet ASTM C-645 and A-653 standards. The properties and weights shown below are calculated on minimum thicknesses in compliance with A.I.S.I. specifications.

Section Properties "DWS"

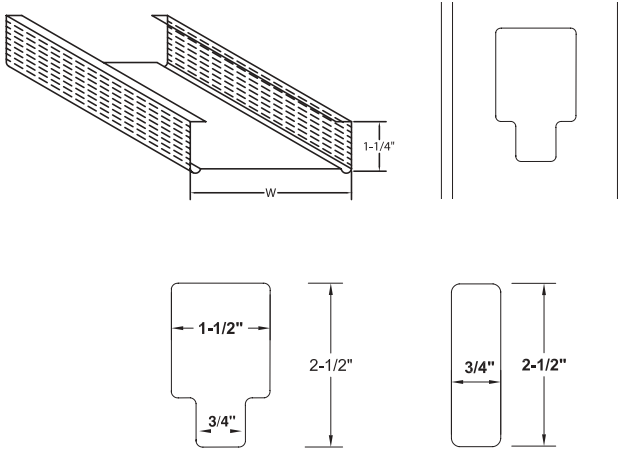

Part#	Web in, (1/100in.)	GA. in., (Mils)	Wt. lb/ft.	A (in ²)	I _x (in ⁴)	S _x (in ³)	Ma (in-K)
162S125-18	1-5/8", (162)	25, (18)	0.27	0.080	0.038	0.046	0.66
162S125-27		22, (27)	0.41	0.120	0.056	0.068	1.01
162S125-30		20, (30)	0.45	0.131	0.061	0.075	1.16
250S125-18	2-1/2", (250)	25, (18)	0.33	0.097	0.099	0.079	1.17
250S125-27		22, (27)	0.49	0.144	0.147	0.118	1.81
250S125-30		20, (30)	0.54	0.159	0.161	0.129	2.06
350S125-18	3-1/2", (350)	25, (18)	0.39	0.115	0.215	0.123	1.72
350S125-27		22, (27)	0.59	0.173	0.320	0.183	2.90
350S125-30		20, (30)	0.65	0.190	0.351	0.201	3.29
362S125-18	3-5/8", (362)	25, (18)	0.40	0.118	0.234	0.129	1.78
362S125-27		22, (27)	0.60	0.176	0.347	0.192	3.05
362S125-30		20, (30)	0.66	0.194	0.381	0.210	3.46
400S125-18	4", (400)	25, (18) ¹	0.42	0.125	0.294	0.147	1.96
400S125-27		22, (27)	0.64	0.187	0.438	0.219	3.52
400S125-30		20, (30)	0.70	0.206	0.481	0.240	3.99
600S125-18	6", (600)	25, (18) ¹	0.55	0.162	0.778	0.259	-
600S125-27		22, (27) ¹	0.83	0.243	1.160	0.387	5.42
600S125-30		20, (30)	0.91	0.268	1.275	0.425	6.54

Limiting Heights Table (Based on 5 PSF Interior Wind Load)

Part#	Web in, (1/100in.)	GA. in., (Mils)	No Sheathing						1/2" Layer Gypsum Board Each Side					
			16" O.C.			24" O.C.			16" O.C.			24" O.C.		
			L/120	L/240	L/360	L/120	L/240	L/360	L/120	L/240	L/360	L/120	L/240	L/360
162S125-18	1-5/8", (162)	25, (18)	8' 8"	6' 11"	6' 0"	7' 7"	6' 0"	5' 3"	10' 7"	8' 4"	-	9' 9"	7' 11"	-
162S125-27		22, (27)	10' 3"	8' 1"	7' 1"	8' 11"	7' 1"	6' 2"	-	-	-	-	-	-
162S125-30		20, (30)*	10' 6"	8' 4"	7' 3"	9' 2"	7' 3"	6' 4"	11' 9"	9' 4"	-	10' 9"	8' 7"	-
162S125-33		20, (33)	10' 10"	8' 7"	7' 6"	9' 6"	7' 6"	6' 7"	12' 1"	9' 8"	8' 5"	11' 0"	8' 9"	7' 8"
250S125-18	2-1/2", (250)	25, (18)	12' 0"	9' 6"	8' 4"	10' 2"	8' 4"	7' 3"	13' 3"	11' 3"	9' 10"	11' 10"	10' 7"	9' 3"
250S125-27		22, (27)	14' 1"	11' 2"	9' 9"	12' 4"	9' 9"	8' 6"	-	-	-	-	-	-
250S125-30		20, (30)*	14' 7"	11' 7"	10' 1"	12' 9"	10' 1"	8' 10"	15' 9"	12' 6"	10' 10"	14' 2"	11' 4"	9' 10"
250S125-33		20, (33)	15' 1"	11' 11"	10' 5"	13' 2"	10' 5"	9' 1"	16' 5"	12' 10"	11' 2"	14' 10"	11' 7"	10' 0"
362S125-18	3-5/8", (362)	25, (18)	15' 1"	12' 9"	11' 2"	12' 7"	11' 2"	9' 9"	15' 4"	14' 4"	12' 4"	13' 9"	13' 5"	11' 7"
362S125-27		22, (27)	18' 9"	14' 11"	13' 0"	16' 5"	13' 0"	11' 4"	-	-	-	-	-	-
362S125-30		20, (30)*	19' 5"	15' 5"	13' 5"	17' 0"	13' 5"	11' 9"	19' 7"	16' 0"	13' 10"	17' 6"	14' 6"	12' 6"
362S125-33		20, (33)	20' 1"	15' 11"	13' 11"	17' 6"	13' 11"	12' 2"	20' 8"	16' 5"	14' 3"	18' 6"	14' 9"	12' 9"
400S125-18	4", (400)	25, (18)	16' 2"	13' 9"	12' 0"	13' 2"	12' 0"	10' 6"	17' 2"	15' 4"	13' 4"	15' 1"	14' 2"	12' 4"
400S125-27		22, (27)	20' 3"	16' 1"	14' 0"	17' 8"	14' 0"	12' 3"	-	-	-	-	-	-
400S125-30		20, (30)*	21' 0"	16' 8"	14' 7"	18' 4"	14' 7"	12' 8"	21' 10"	17' 8"	15' 4"	19' 7"	15' 11"	13' 10"
400S125-33		20, (33)	21' 8"	17' 3"	15' 0"	18' 11"	15' 0"	13' 2"	23' 1"	18' 4"	15' 11"	20' 9"	16' 5"	14' 3"
600S125-18	6", (600)	25, (18)	-	-	-	-	-	19' 9"	19' 9"	17' 11"	16' 9"	16' 9"	16' 9"	-
600S125-27		22, (27)	26' 10"	22' 4"	19' 6"	21' 11"	19' 6"	17' 1"	-	-	-	-	-	-
600S125-30		20, (30)*	29' 1"	23' 1"	20' 2"	24' 1"	20' 2"	17' 7"	28' 7"	23' 6"	20' 7"	25' 1"	20' 7"	18' 4"
600S125-33		20, (33)	30' 1"	23' 11"	20' 10"	26' 3"	20' 10"	18' 3"	30' 10"	24' 6"	21' 4"	27' 2"	21' 7"	18' 10"

Note: Additional sizes and gages are available upon request.

Foot Notes:

D- Distance between the centroid of the section and the web center.
 I_x- Moment of inertia for deflection about the x-axis.
 S_x- Section modulus for load about the x-axis.
 Ma- Allowable resisting moment. Listed values incorporate the effects of cold forming as allowed per section A7.2 of the 2002 A.I.S.I. "Specification for Design of Cold Formed Steel Structural Members."

Notes for the Limiting Heights Table:

- To attain values listed, attachment of drywall stud to runner track with (1) type S drywall screwed to each side, top and bottom, is required. If facing material is not applied to both sides of the framing then horizontal bridging is required. The spacing of this bridging shall not exceed 5' 0" O.C.
- Calculated values based on 33ksi yield strength.

Note for the Limiting Height With Gypsum Board Table:

Drywall installation shall be in accordance with A.S.T.M. C840-99a "Application and Finishing of Gypsum Board"

The following are thickness for Telling Industries' drywall products:

Gauge	In.	Mils
25 ga.	0.018	18
22 ga.	0.027	27
20 ga.	0.03	30

Limiting Heights Table (Based on 7.5 PSF Interior Wind Load)

Part#	Web in. (1/100in.)	GA. in., (Mils)	No Sheathing						1/2" Layer Gypsum Board Each Side					
			16" O.C.			24" O.C.			16" O.C.			24" O.C.		
			L/120	L/240	L/360	L/120	L/240	L/360	L/120	L/240	L/360	L/120	L/240	L/360
162S125-18	1-5/8", (162)	25, (18)	7' 7"	6' 0"	5' 3"	6' 2" f	5' 3"	4' 7"	8' 10" f	-	-	8' 0" f	-	-
162S125-27		22, (27)	8' 11"	7' 1"	6' 2"	7' 9"	6' 2" f	5' 5"	-	-	-	-	-	-
162S125-30		20, (30)*	9' 2"	7' 3"	6' 4"	8' 0"	6' 4"	5' 7"	-	-	-	-	-	-
162S125-33		20, (33)	9' 6"	7' 6"	6' 7"	8' 3"	6' 7"	5' 9"	10' 7"	8' 5"	-	9' 7"	7' 8"	-
250S125-18	2-1/2", (250)	25, (18)	10' 2" f	8' 4"	7' 3"	8' 4" f	7' 3"	6' 4"	10' 10" f	9' 10"	8' 7"	9' 8" f	9' 3"	8' 1"
250S125-27		22, (27)	12' 4"	9' 9"	8' 6"	10' 4" f	8' 6"	7' 5"	-	-	-	-	-	-
250S125-30		20, (30)*	12' 9"	10' 1"	8' 10"	11' 0" f	8' 10"	7' 8"	-	-	-	-	-	-
250S125-33		20, (33)	13' 2"	10' 5"	9' 1"	11' 6"	9' 1"	7' 11"	14' 4"	11' 2"	9' 8"	13' 0"	10' 0"	8' 7"
362S125-18	3-5/8", (362)	25, (18)	12' 4" f	10' 10"	9' 6"	10' 1" f	9' 6"	9' 8"	12' 5" f	12' 5"	10' 10"	11' 0" f	11' 0" f	10' 1"
362S125-27		22, (27)	15' 11"	12' 8"	11' 0"	13' 1" f	11' 0"	11' 4"	-	-	-	-	-	-
362S125-30		20, (30)*	16' 6"	13' 1"	11' 5"	13' 11" f	11' 5"	10' 0"	-	-	-	-	-	-
362S125-33		20, (33)	17' 1"	13' 6"	11' 10"	14' 11"	11' 10"	10' 4"	18' 1"	14' 3"	12' 6"	16' 2"	12' 9"	11' 2"
400S125-18	4", (400)	25, (18)	13' 2" f	12' 0"	10' 6"	10' 9" f	10' 6"	9' 2"	13' 10" f	13' 4"	11' 8"	12' 1" f	12' 1" f	10' 9"
400S125-27		22, (27)	17' 8"	14' 0"	12' 3"	14' 5" f	12' 3"	10' 8"	-	-	-	-	-	-
400S125-30		20, (30)*	18' 4"	14' 7"	12' 8"	15' 4" f	12' 8"	11' 1"	-	-	-	-	-	-
400S125-33		20, (33)	18' 11"	15' 0"	13' 2"	16' 5" f	13' 2"	11' 6"	22' 2"	15' 11"	13' 9"	18' 1"	14' 3"	12' 4"
600S125-18	6", (600)	25, (18)	-	-	-	-	-	-	16' 2" f	16' 2" f	15' 7"	13' 5" f	13' 5" f	13' 5" f
600S125-27		22, (27)	21' 11" f	19' 6"	17' 1"	17' 11"	17' 1"	14" 11"	-	-	-	-	-	-
600S125-30		20, (30)*	24' 1" f	20' 2"	17' 7"	19' 8"	17' 7"	15' 5"	-	-	-	-	-	-
600S125-33		20, (33)	26' 3"	20' 10"	18' 3"	21' 10" f	18' 3"	15' 11"	27' 0"	21' 4"	18' 9"	23' 10"	18' 10"	16' 7"

Limiting Heights Table (Based on 10 PSF Interior Wind Load)

Part#	Web in. (1/100in.)	GA. in., (Mils)	No Sheathing						1/2" Layer Gypsum Board Each Side					
			16" O.C.			24" O.C.			16" O.C.			24" O.C.		
			L/120	L/240	L/360	L/120	L/240	L/360	L/120	L/240	L/360	L/120	L/240	L/360
162S125-18	1-5/8", (162)	25, (18)	6' 7" f	5' 5"	4' 9"	5' 4" f	4' 9"	4' 2"	8' 4"	-	-	-	-	-
162S125-27		22, (27)	8' 1"	6' 5"	5' 7"	6' 8" f	5' 7"	4' 11"	-	-	-	-	-	-
162S125-30		20, (30)*	8' 4"	6' 7"	5' 9"	7' 2" f	5' 9"	5' 0"	-	-	-	-	-	-
162S125-33		20, (33)	8' 7"	6' 10"	6' 0"	7' 6"	6' 0"	5' 2"	9' 8"	-	-	8' 9"	-	-
250S125-18	2-1/2", (250)	25, (18)	8' 10" f	7' 7"	6' 7"	7' 2" f	6' 7"	5' 9"	9' 5" f	8' 11"	-	8' 5" f	8' 5"	-
250S125-27		22, (27)	10' 11" f	8' 10"	7' 9"	8' 11" f	7' 9"	6' 9"	-	-	-	-	-	-
250S125-30		20, (30)*	11' 7"	9' 2"	8' 0"	9' 6" f	8' 0"	7' 0"	-	-	-	-	-	-
250S125-33		20, (33)	11' 11"	9' 6"	8' 3"	10' 3" f	8' 3"	7' 3"	12' 10"	10' 0"	8' 8"	11' 7"	8' 11"	7' 8"
362S125-18	3-5/8", (362)	25, (18)	10' 8" f	9' 10"	8' 7"	8' 9" f	8' 7"	7' 6"	10' 9" f	10' 9" f	9' 9"	9' 5" f	9' 5" f	9' 1"
362S125-27		22, (27)	13' 10" f	11' 6"	10' 0"	11' 4" f	10' 0"	8' 9"	-	-	-	-	-	-
362S125-30		20, (30)*	14' 9" f	11' 11"	10' 5"	12' 1" f	10' 5"	9' 1"	-	-	-	-	-	-
362S125-33		20, (33)	15' 6"	12' 4"	10' 9"	12' 11" f	10' 9"	9' 4"	16' 5"	12' 11"	11' 4"	14' 9"	11' 7"	10' 1"
400S125-18	4", (400)	25, (18)	11' 5" f	10' 11"	9' 6"	9' 4" f	9' 4" f	8' 4"	11' 11" f	11' 11" f	10' 6"	10' 5" f	10' 5" f	9' 9"
400S125-27		22, (27)	15' 3" f	12' 9"	11' 2"	12' 6" f	11' 2"	9' 9"	-	-	-	-	-	-
400S125-30		20, (30)*	16' 3" f	13' 3"	11' 6"	13' 3" f	11' 6"	10' 1"	-	-	-	-	-	-
400S125-33		20, (33)	17' 3"	13' 8"	11' 11"	14' 2" f	11' 11"	10' 5"	18' 4"	14' 5"	12' 6"	16' 5"	12' 10"	11' 2"
600S125-18	6", (600)	25, (18)	-	-	-	-	-	-	14' 0" f	14' 0" f	13' 10"	11' 5" f	11' 5" f	11' 5" f
600S125-27		22, (27)	19' 0" f	17' 9"	15' 6"	15' 6" f	15' 6" f	13' 6"	-	-	-	-	-	-
600S125-30		20, (30)*	20' 10" f	18' 4"	16' 0"	17' 0" f	16' 0"	14' 0"	-	-	-	-	-	-
600S125-33		20, (33)	23' 2" f	18' 11"	16' 6"	18' 11" f	16' 6"	14' 5"	24' 6"	19' 5"	17' 0"	19' 1" s	17' 2"	15' 0"

* Composite values based on interpolation of test data. f: Flexural stress controls allowable wall height. s: Sheer/web crippling controls allowable wall height
 1: Web-height to thickness ratio exceeds 200. Web stiffeners required at all support points and concentrated loads.

DRYWALL FRAMING ACCESSORIES



(DWFC) Drywall Furring Channel

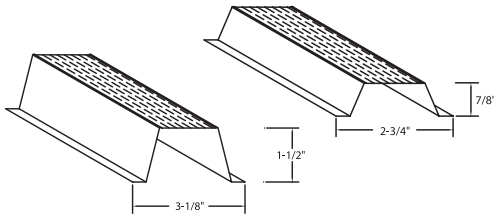

Product Data:

- Available in 7/8" and 1-1/2" sizes.
- Gauge: Standard 25 Ga., also in 22, 20, 18, and 16 gauges.
- Lengths: Standard stock 12' 0", (other lengths available upon request). Consult Telling Industries' Light Gage Structural Framing & Accessories brochure for structural properties and span tables

Product	Ga.	Wt./Ft.
DWFC 088-18	25	0.275
DWFC 088-30	20	0.477
DWFC 150-18	25	0.345
DWFC 150-30	20	0.599

Uses:

- Convenient accessory components for use in furring out ceilings and masonry walls. Knurled face prevents screw "ride" when attaching gypsum wallboard.
- 1-1/2" DWFC is economical with respect to furring walls with electrical boxes, (no need to set into concrete).

(RC) Resilient Furring Channel

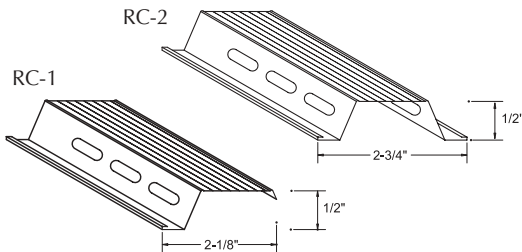

Product Data:

- RC-1: Single Leg • RC-2: Double Leg
- Gauge: Standard 25 gage conforming to ASTM A-653 and C-645.
- Lengths: 12' 0" stock length
- RC-1: Screw attachment, one side only.
- RC-2: Screw attachment, both sides.

Product	Length	Wt./Ft.	Pcs./Ctn.	Ft./Ctn.
RC-1	12'	0.20	40	480
RC-2	12'	0.24	40	480

Uses:

- Used as cross furring members for resilient attachment of gypsum wallboard or lath on ceilings and partitions.
- Decreases sound transmission through wall partitions and ceilings.

(ZFC) Z-Furring Channel

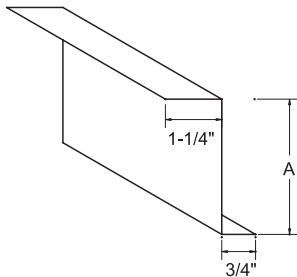

Product Data:

- Available in hot-dipped galvanized steel conforming to ASTM A-653 and C-645.
- Gauges: Standard 25 gauge, (available in 22, 20, 18, and 16 gauge upon request).
- Lengths: Standard 10' 0" and 8' 6" lengths, (other lengths available upon request).

Product	(A) in. Size	25 Ga. Wt./Ft.
Z-100	1.00	0.195
Z-150	1.50	0.225
Z-200	2.00	0.260

Uses:

- Designed to accommodate the installation of rigid insulation board while providing an attachment for drywall or other facing materials to the interior side of masonry or monolithic concrete walls.

Note: Additional sizes and gages are available upon request.

(CRC) Cold-Rolled Channel

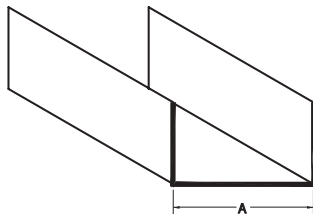

Product Data:

- Available in galvanized steel meeting ASTM A-568 or hot-dipped galvanized steel meeting ASTM A-653, G60.
- Lengths: 16' 0" standard, (other lengths available upon request).

Product	(A) in. Size	Ga.
CRC-075	0.75	16
CRC-150	1.50	16

Uses:

- Bridging, (lateral support) in walls carrying axial and/or wind loads.
- Bracing studs at door bucks and furring for ceilings.
- Used in conjunction with metal lath and plaster in partitions, ceilings, column and beam enclosures, etc.

For physical structural properties and span tables consult Telling Industries Light Gage Structural Framing & Accessories brochure.

(RA) Rolled Angles

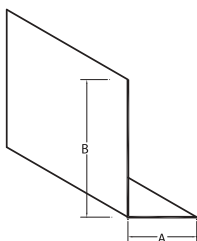

Product Data:

- Available in most sizes, lengths, and gauges.

Uses:

- For 90 degree corner enclosures at lapped framing location; provides in-plane stability of framework.

(AxB) Product	Gauges	Length
1-1/2" x 1-1/2"	25, 22, 20, 18, 16	10'
2" x 2"	25, 22, 20, 18, 16, 14	10'

Note: Additional sizes and gages are available upon request.

(FS) Flat Strapping

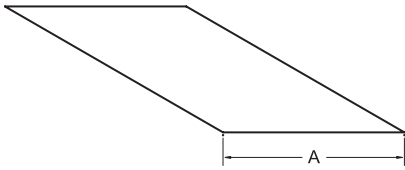

Product Data:

- Designation: FS width and gauge.
- Widths: 2, 4 and 6" (custom widths and coil available).

Uses:

- Provides tension force resistance in shear wall assemblies.
- Resists racking of prefabricated wall assemblies while handling, transporting, and erecting.

Note: Custom width and lengths available upon request.

Specify length, width and gauge when ordering.

Product	Width (in.)	Gauges	Length
FS	2", 4", 6"	25, 22, 20, 18, 16	10'

(DCB) Drywall Corner Bead

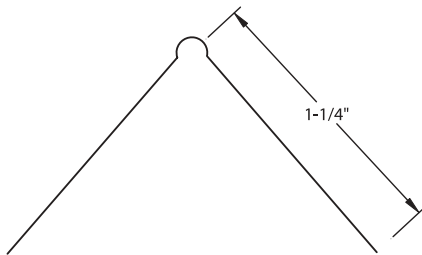

Product Data:

- Made of galvanized steel.
- Joint cement adheres easily to knurled flanges and keys into the perforations.
- Exposed nose provides a straight, clean corner definition and guards against damage through impact.

Uses:

- Provides durable protection for drywall external corners.
- Specify hot-dipped for moist or humid conditions.

Product	Size/Depth	Length (ft.)	Pcs./Ctn.	Ft./Ctn.
DCB	1-1/4" x 1-1/4"	8', 9', 10', 12'	80, 60, 60, 80	640, 540, 600, 960

J Bead

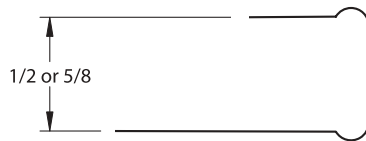

Product Data:

- Sturdy, channel-type steel casing.
- Joint cement applied to front side.
- L Bead available in both regular and long-leg flange.
- Easily installs to framing or jamb.

Uses:

- Provides maximum protection.
- Adds a finished edge to wallboard at window and door jambs

Custom lengths and UPC labeling available upon request.

L Bead



Product	Size/Depth	Length (ft.)	Pcs./Ctn.	Ft./Ctn.
L-50, J-50	1/2" or 5/8"	8', 10'	63, 50	504, 500
L-62, J-62	"	"	"	"

(RT) Reveal Trim

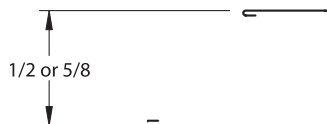

Product Data:

- An economical steel channel.
- No joint cement required.

Uses:

- Provides edge protection around doors and windows or any partition junction openings.

Custom lengths and UPC labeling available upon request.

Product	Size/Depth	Length (ft.)	Pcs./Ctn.	Ft./Ctn.
RT-50, RT-62	1/2" & 5/8"	8', 10'	63, 50	504, 500

093 Expansion Control Joint



Product Data:

- Manufactured from the highest quality pure zinc coil stock for superior corrosion resistance.
- Fits standard 1/4" openings.

Uses:

- Product is excellent for interior or exterior applications.

Product	Length (ft.)	Pcs./Ctn.	Ft./Ctn.
093	10'	25	250

General Product Information

Raw Material Information

All Telling Industries products are formed from steel with a minimum yield strength of 33 or 50 KSI (1000 lbs per square inch). All products contained in this brochure are engineered to meet the 2001 Edition of the AISI (American Iron and Steel Institute) *North American Specification for the Design of Cold-Formed Steel Structural Members*. The same document was used to calculate the physical and structural properties of all products listed herein via allowable stress design criteria.

Technical Assistance

Technical assistance is available to Telling Industries customers when requested. A Telling Industries representative or design professional can review project specific load conditions and determine deflection criteria and lateral bracing conditions not discussed herein. Further, our representatives can assist purchasers and designers in economical applications for maximum efficiency.

Disclaimer

All information contained in this brochure is intended as a general guide for using Telling Industries' products. This information should not be used in design or assembly without an

independent assessment by a qualified design professional. Such an assessment is necessary to verify the suitability of a particular product for use in any load bearing application. Telling Industries assume no liability for failure resulting from the use or misapplications of any information contained herein. Detail drawings contained here in are for information only. Telling Industries reserve the right to make modifications, changes, additions or deletions to the information on any of our products without prior notice or obligation. For the latest product information or to verify availability, contact a Telling Industries representative. This brochure contains the latest information available at the time of printing.

General Notes for all Tables

- The strength increase due to cold work forming was incorporated for flexural strength as applicable per AISI A7.2.
- The moment of inertia for deflection is calculated at a stress which results in an effective section modulus such that the stress times that section modulus is equal to the allowable moment. This follows Procedure 1 of the AISI specification.
- The yield stresses (33 ksi or 50 ksi) used to calculate the tabulated values are indicated in the tables.
- When provided, factory punch-outs will be located along the centerline of the webs of the members and will have a minimum center-to-center spacing of 24". Punch-outs will have a maximum width = half the member web height (d/2) or 1 1/2", whichever is less, and a maximum length = 4". The minimum distance between the end of the member and the near edge of the web punch-out = 10" unless otherwise specified.
- For those steels that have both 33 and 50 ksi listings, if the design is based upon 50 ksi, the 50 ksi steel needs to be specified by the designer/purchasers. (i.e., 362S137-54 (50 ksi))

Definitions of Structural Property Symbols

Gross Properties

- Ixx:** Moment of inertia of the gross section about the X-X axis (strong axis).
Rx: Radius of gyration of the gross section about the X-X axis.
Iyy: Moment of inertia of the gross section about the Y-Y axis (weak axis).
Ry: Radius of gyration of the gross section about the Y-Y axis.

Effective Properties

- Ixx:** Moment of inertia for deflection calculations based on the "Procedure 1 for Deflection Determination" of the 2001 AISI Specification.
Sxx: Effective section modulus about the X-X axis (strong axis) $\text{Stress} = F_y$
Ma: Allowable Bending Moment- Based on the effective section modulus and the allowable stress including the strength increase from cold-work of forming (AISI A 7.2) where applicable.
Va: Allowable Shear Load.
Ycg: Maximum distance from the outside of the compression flange to the center of gravity of the effective section.

Torsional Properties

- J:** St. Venant Torsional Constant.
Cw: Torsional warping constant.
Xo: Distance from the shear center to the centroid along the principal X-axis.
Ro: Polar radius of gyration about the centroid principal axis.
f: $1 - (Xo/Ro)^2$

Section Properties Table Notes

- The centerline bend radius is the greater of 2 times the design thickness or 3/32"
- Web depth for track sections is equal to the nominal height plus 2 times the design thickness plus the bend radius.
- Hems on non-structural track sections are ignored.
- Effective properties incorporate the strength increase from the cold work of forming as applicable per AISI A7.2.
- Tabulated gross properties are based on the full-unreduced cross section of the studs, away from punchouts.
- For deflection calculations, use the effective moment of inertia.
- For those steels that have both 33 and 50 ksi, the 50 ksi steel needs to be specified. (i.e., 362S137-54 (50 ksi))

Thickness - Steel Components

Minimum Thickness ¹ (mils)	Design Thickness (in)	Inside Corner Radii (in)	Reference Only Gauge No.
18	0.0188	0.0843	25
27	0.0283	0.0796	22
30	0.0312	0.0781	20 - Drywall
33	0.0346	0.0764	20 - Structural
43	0.0451	0.0712	18
54	0.0566	0.0849	16
68	0.0713	0.1069	14
97	0.1017	0.1525	12

Design Stiffening Lip Length

Section	Flange Width	Design Stiffening Lip Length (in)
S125	1 1/4"	0.188
S137	1 3/8"	0.375
S162	1 5/8"	0.500
S200	2"	0.625
S250	2 1/2"	0.625

¹Minimum Thickness represents 95% of the design thickness and is the minimum acceptable thickness delivered to the job site based on Section A2.4 of the 2001 AISI Specification.



Telling Industries
 2105 Larrick Road
 Cambridge, OH 43725
 Tel: 740-435-8900 • Fax: 740-435-8915
www.tellingindustries.com